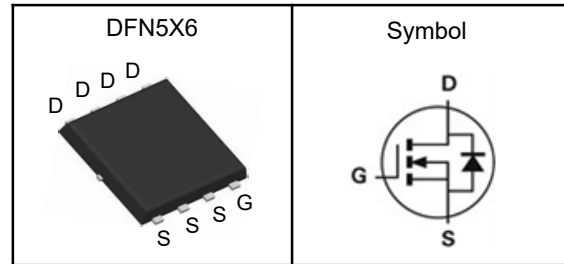

N-Channel Enhancement Mode MOSFET
Features

- High Speed Power Switching
- Reliable and Rugged
- ROHS Compliant
- 100% Avalanche Tested

Applications

- Power Management in Desktop Computer
- DC/DC Converters

Pin Description

V_{DSS}	100	V
$R_{DS(ON)-Typ}$	12	m Ω
I_D	41	A

Absolute Maximum Ratings ($T_C=25^{\circ}C$, Unless Otherwise Noted)

Symbol	Parameter	N-Channel	Unit
V_{DSS}	Drain-Source Voltage	100	V
V_{GSS}	Gate-Source Voltage	± 20	V
T_J	Maximum Junction Temperature	-55 to 150	$^{\circ}C$
T_{STG}	Storage Temperature Range	-55 to 150	$^{\circ}C$
$I_{DM}^{①}$	Pulse Drain Current Tested	71	A
I_D	Continuous Drain Current	41	A
P_D	Maximum Power Dissipation	46	W
E_{AS}	Avalanche Energy, Single pulse	5	mJ

Thermal Characteristics

Symbol	Parameter	Rating	Unit
$R_{\theta JA}$	Thermal Resistance-Junction to Ambient	50	$^{\circ}C/W$
$R_{\theta JC}$	Thermal Resistance-Junction to Case	2.7	$^{\circ}C/W$

Note ① : Max. current is limited by bonding wire.

Note ② : UIS tested and pulse width are limited by maximum junction temperature 150 $^{\circ}C$.

Note ③ : Surface Mounted on 1in² FR-4 board with 1oz.



N-Channel Enhancement Mode MOSFET

Electrical Characteristics ($T_J=25^{\circ}\text{C}$, Unless Otherwise Noted)

Symbol	Parameter	Test Conditions	Min	Typ	Max	Unit
Static Electrical Characteristics						
BV_{DSS}	Drain-Source Breakdown Voltage	$V_{GS}=0V, I_D=250\mu A$	100	---	---	V
I_{DSS}	Zero Gate Voltage Drain Current	$V_{DS}=80V, V_{GS}=0V$	---	---	1	μA
$V_{GS(th)}$	Gate Threshold Voltage	$V_{DS}=V_{GS}, I_D=250\mu A$	1	---	3	V
I_{GSS}	Gate Leakage Current	$V_{GS}=\pm 20V, V_{DS}=0V$	---	---	± 100	nA
$R_{DS(on)}$	Drain-Source On-state Resistance	$V_{GS}=10V, I_D=12A$	---	12	15	$m\Omega$
		$V_{GS}=4.5V, I_D=8A$	---	19	25	$m\Omega$
Dynamic Characteristics ^⑤						
gfs	Forward Transconductance	$V_{DS}=5V, I_D=20A$	---	22	---	S
R_g	Gate Resistance	$V_{DS}=0V, V_{GS}=0V, f=1MHz$	---	3	---	Ω
C_{iss}	Input Capacitance	$V_{DS}=50V, V_{GS}=0V, Freq.=1MHz$	---	1055	---	pF
C_{oss}	Output Capacitance		---	182	---	
C_{rss}	Reverse Transfer Capacitance		---	5	---	
$T_{d(on)}$	Turn-on Delay Time	$V_{DS}=50V, V_{GS}=10V, I_D=1A, R_G=3\Omega$	---	6	---	nS
T_r	Turn-on Rise Time		---	15	---	
$T_{d(off)}$	Turn-off Delay Time		---	16	---	
T_f	Turn-off Fall Time		---	25	---	
Q_g	Total Gate Charge	$V_{DS}=50V, V_{GS}=10V, I_D=12A$	---	22.5	---	nC
Q_{gs}	Gate-Source Charge		---	3.2	---	
Q_{gd}	Gate-Drain Charge		---	7.6	---	
Source-Drain Characteristics						
V_{SD}	Diode Forward Voltage	$I_S=20A, V_{GS}=0V$	---	---	1.1	V
t_{rr}	Reverse Recovery Time	$I_F=20A, V_R=50V, di_F/dt=100A/\mu s$	---	40	---	nS
Q_{rr}	Reverse Recovery Charge		---	59	---	nC

Note ④: Pulse test (pulse width $\leq 300\mu s$, duty cycle $\leq 2\%$).

Note ⑤: Guaranteed by design, not subject to production testing.

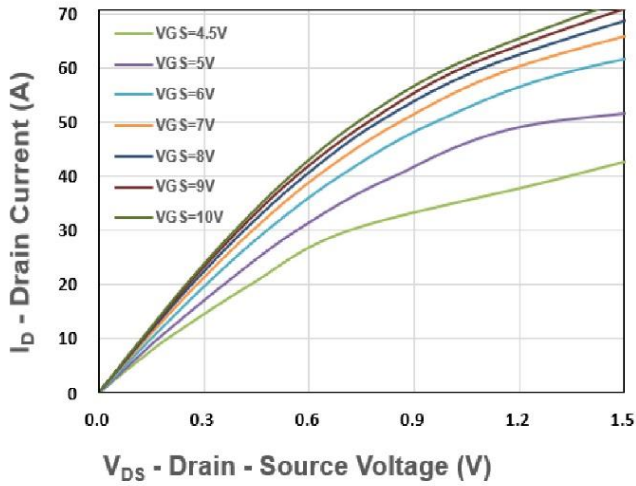
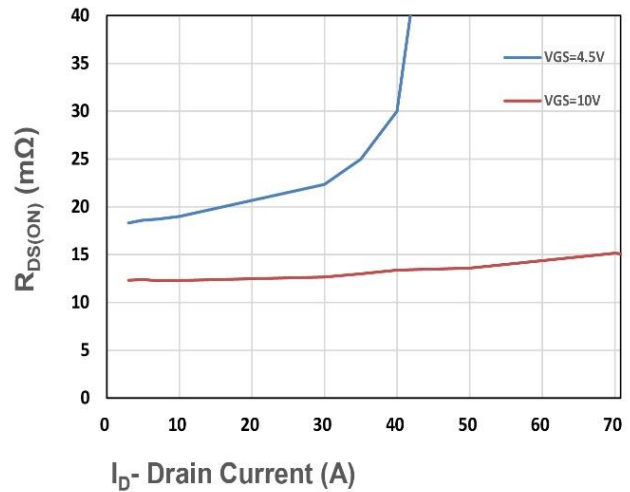
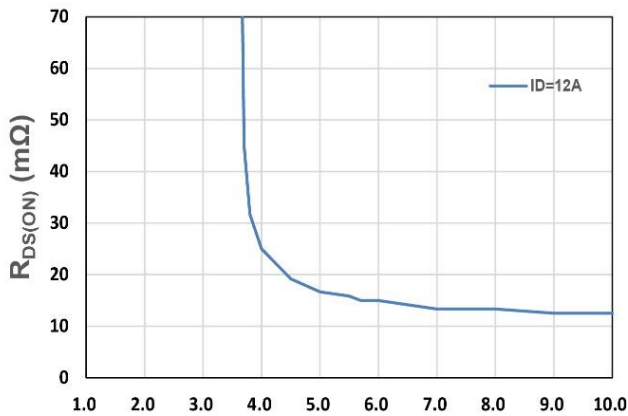
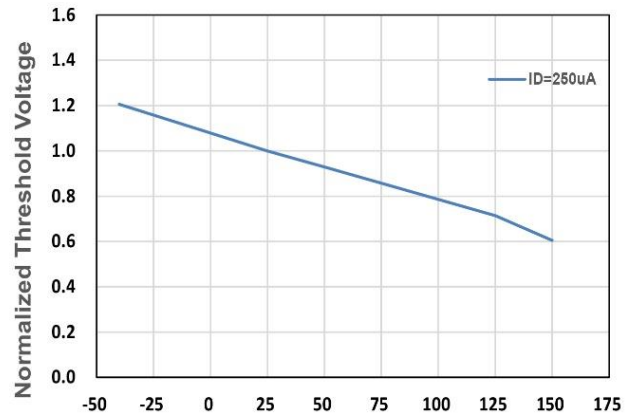
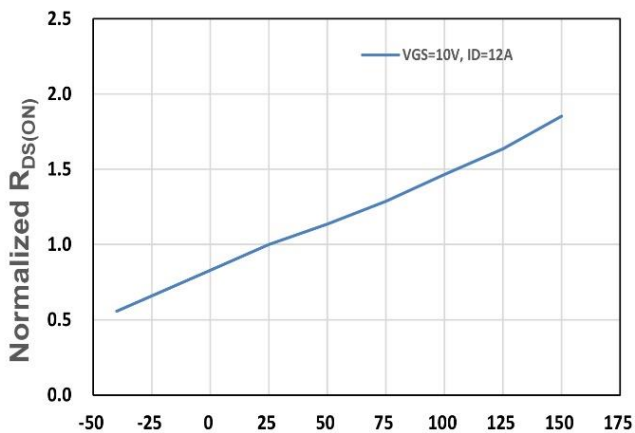
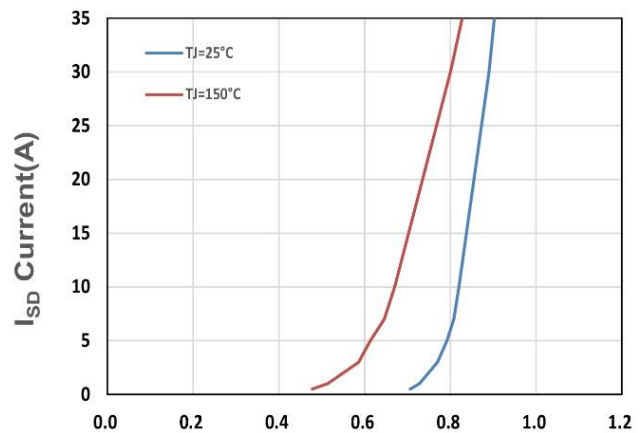
N-Channel Enhancement Mode MOSFET
Typical Characteristics

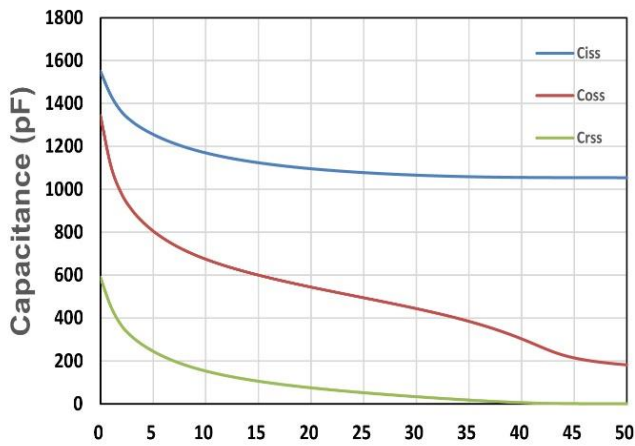
Figure 1. Output Characteristics

Figure 2. On-Resistance vs. ID

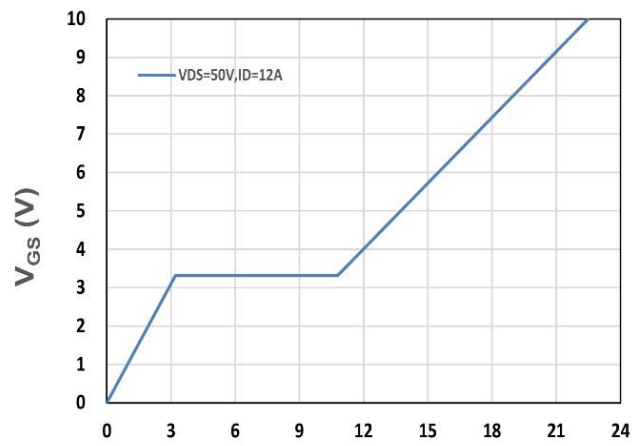
Figure 3. On-Resistance vs. VGS

Figure 4. Gate Threshold Voltage

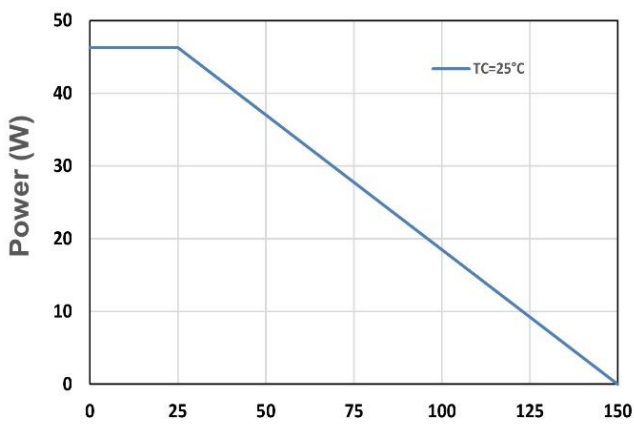
Figure 5. Drain-Source On Resistance

Figure 6. Source-Drain Diode Forward

N-Channel Enhancement Mode MOSFET

V_{DS} - Drain - Source Voltage (V)
Figure 7. Capacitance



Q_g, Total Gate Charge (nC)
Figure 8. Gate Charge Characteristics



T_j - Junction Temperature (°C)
Figure 9. Power Dissipation

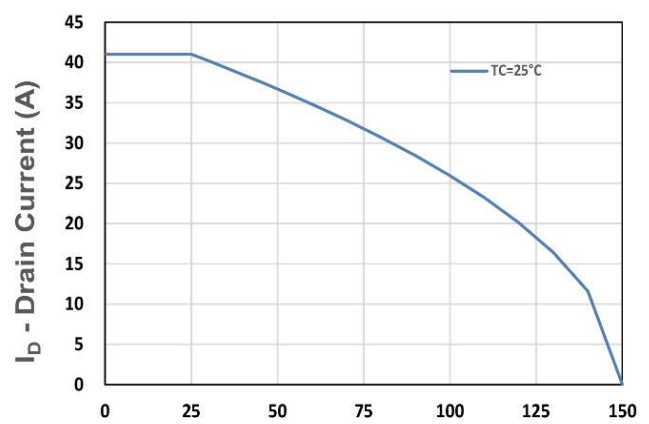

T_j - Junction Temperature (°C)
Figure 10. Drain Current

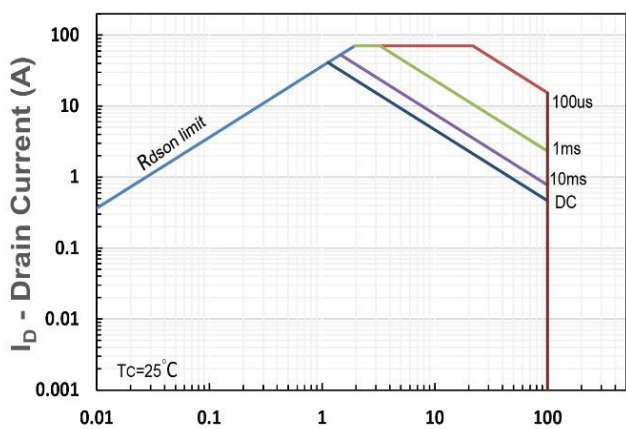

V_{DS} - Drain-Source Voltage (V)
Figure 11. Safe Operating Area

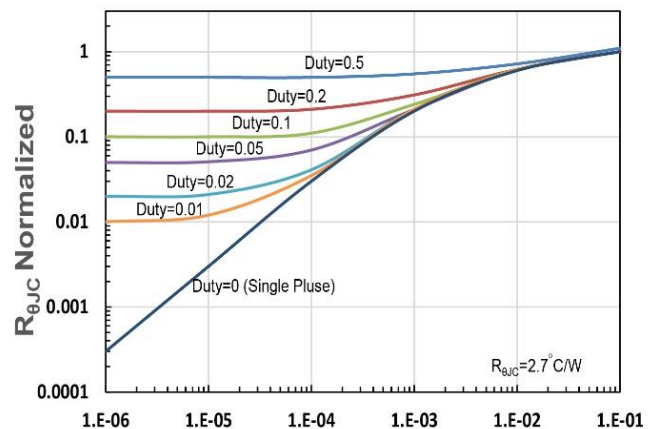

t₁, Square Wave Pulse Duration(s)
Figure 12. R_{θJC} Transient Thermal Impedance

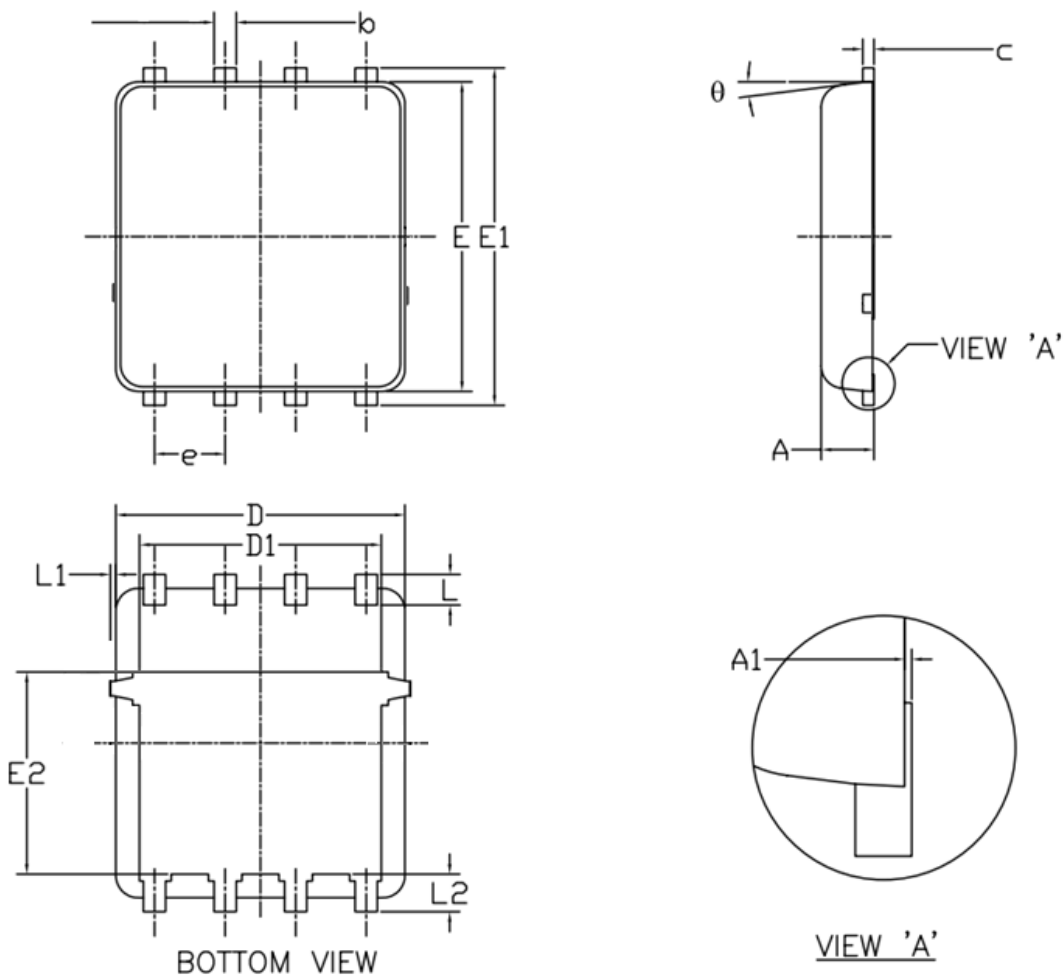
N-Channel Enhancement Mode MOSFET
DFN5X6-8L Package Outline Dimensions

Symbol	Dimensions (unit:mm)			Symbol	Dimensions (unit:mm)		
	Min	Typ	Max		Min	Typ	Max
A	0.90	1.00	1.20	E1	5.90	6.10	6.35
A1	0.00	--	0.05	E2	3.38	3.58	3.92
b	0.30	0.40	0.51	e	1.27 BSC		
c	0.20	0.25	0.33	L	0.51	0.61	0.71
D	4.80	4.90	5.40	L1	--	--	0.15
D1	3.61	4.00	4.25	L2	0.41	0.51	0.61
E	5.65	5.80	6.06	θ	0°	--	12°